

EGOLF RECOMMENDATION 055rev1-2019

Subject of Recommendation	Testing linear products in the SBI
Related test standard	EN 13823 – EN ISO 11925-2
Date of issue	2026-01-29
Reference original query	
Previous publication number (if applicable)	
Keywords (max. 20)	Linear product, SBI, EN 13823, pipe, ducts, seals and gaskets

Problem

At the meeting of TC1 in October 2017, the solution given to helpdesk item 2017-06 (N666) referred to a specific product, of plastic pipes. In order to provide a better basis for discussion in the EGOLF meeting in April 2018, Giombattista Traina of Istituto Giordano supplied a summary of different solutions for different products and circulated them via the helpdesk forum before the meeting for members to respond. The following text includes the comments received prior to 31st December 2018 plus additional information from TUM and Istituto Giordano, as agreed in TC1 meeting April 2019.

Recommendation

The main criterion to be used in order to find the correct mounting and fixing for the SBI test of a linear product is to simulate its end-use application, as specified in EN 13823, clause 5.2.1 (test according to the intended use), not clause 5.2.2 (standard mounting and fixing).

Warning concerning products which are not linear insulation products: The classified end use must be representative of the tested setup. Wording example: “The classification is only valid for a product length of 5,5 m per every 2,25 m² and a distance \geq 100 mm between the individual linear products”.

Many linear products can be tested according to a specific EN standard or EGOLF Agreement; therefore similar products with the same end-use application should be tested following the same rules. This document gives a detailed indication of how to test a large number of various linear products. For colour variation, EGOLF Recommendations should be used for any kind of product. The choice of substrate for any product is based on EN 13238.

If not defined otherwise in the paragraph specified, when testing a family of products, minimum and maximum parameters shall be tested as indicative and two more tests shall be added for the worst-case scenario.

For linear insulation products, if not covered by harmonized product standards, EN 15715 shall be applied and the classification as linear pipe insulation product shall be used as per clause 10 of EN 13501-1. Any other linear product (also insulated pipe/tubes) shall be classified according to clause 8 of EN 13501-1.

See Figure 1 for a decision flow chart.

Normative references

In order to test a linear product according to EN 13823, the following standards and documents should be applied:

- EN 16000 - Plastics piping systems - Systems within the building structure - Mounting and fixing of components in the test apparatus to thermal attack by a single burning item
- EN 15651-2 - Sealants for non-structural use in joints in buildings and pedestrian walkways
- EN 15266 - Stainless steel pliable corrugated tubing kits in buildings for gas with an operating pressure up to 0,5 bar
- EN 14800 - Corrugated safety metal hose assemblies for the connection domestic appliances using gaseous fuels
- EN 15715:2009 - Thermal insulation products - Instructions for mounting and fixing for reaction to fire testing
- EN 15012 - Plastics piping systems - Soil and waste discharge systems within the building structure - Performance characteristics for pipes, fittings and their joints
- EN 15015 - Plastics piping systems for hot and cold water not intended for human consumption Performance characteristics for pipes, fittings and their joints
- EN 13963 - Jointing materials for gypsum boards
- EGR 010-2017 - SBI test for non-flat products
- EGA 004-2016 - Joints for pipe insulation in the SBI
- EGA 003-2016 - Wall thickness of pipe insulation made out of FEF (flexible elastomeric foam)
- EGA 014-2016 - Pipe insulation products with inner diameters > 22 mm
- EGA 018-2016 - System chimneys with plastic flue liners
- EGA 019-2016 - Flexible air ducts & PVC/PP plastic ducts to protect electrical wires
- EGA 029-2016 - Product orientation in the SBI
- EN 15725 - Extended application reports on the fire performance of construction products and building elements
- EN 13823 - Reaction to fire tests for building products — Building products excluding floorings exposed to the thermal attack by a single burning item
- EN 15447 - Mounting and fixing in reaction to fire tests under the Construction Products Directive
- EN ISO 6927 - Buildings and civil engineering works, Sealants – Vocabulary
- EAD 350141-00-1106 Linear joint and gap seals
- EAD 350454-00-1104 Fire stopping and fire sealing products - Penetration seals
- EN 15701 - Plastics Thermoplastic jackets for insulation products for building equipment and industrial installations Requirements and test methods
- EN 14209 - Preformed plasterboard cornices
- EN 14471 - Chimneys — System chimneys with plastic flue liners
- EN 17192 - Ventilation for buildings - Ductwork - Non-metallic ductwork

Terms and definitions

seal (verb): place the appropriate products in the joint in order to prevent the penetration of water, moisture and/or air between the elements, components and assemblies made of the same or dissimilar materials

sealant: material applied in an unformed state which, once cured or dried has the adhesive and cohesive properties to seal a joint

gasket: material applied in a well-defined shape and form to seal a joint

tab.1 decision tool

Type of product	Type of Mounting	Classification EN 13501-1
Pipe Insulation	EN 15715 clause 5.3.2.8 and cl.* 1.0	clause 10 (A _L ...F _L)
Insulated Pipe/Tube	EN 15715 clause 5.3.2.8 and cl.* 2.0	clause 8 (A1...F)
Chimneys – Handrails	EN 14471 and EGA 018 (see cl.* 3.0)	clause 8 (A1...F),
Tubes For Gas, Compressed Air, Flexible Water Supply	EN 14800 – EN 15266; see cl.* 4.0, 4.1(or 7.0), 4.2	clause 8 (A1...F),
Non-Pressure Plastics Piping	EN 16000, EN 15012, EN 15015, and cl.* 5.0	clause 8 (A1...F),
Sealing Products GASKETS	cl.* 6.3 : EAD 350141-00-1106 – fire stopping product linear joint and gap seals, or cl.* 6.1 or 6.2	clause 8 (A1...F)
Sealing Products SEALANTS	EN 15651-2 and cl.* 6.2 - Sealants for non-structural use in joints in buildings and pedestrian walkways. cl.* 6.5 : EAD 350141-00-1104 fire sealing products – penetration seals	clause 8 (A1...F)
Air Ducts And Plastic Ducts For Wire	see cl.* 7.0	clause 8 (A1...F)
Adhesive Tapes	see cl.* 8.0	clause 8 (A1...F)
Thermoplastic Jackets For Insulation Products	EN 15715 clause 5.3.2.8 and cl.* 9.0	clause 10 (A _L ...F _L)
Preformed Plasterboard Cornices	EN 14209 see cl.* 10.0	clause 8 (A1...F)
Ductwork - Non-Metallic Ductwork	EN 17192 see cl.* 11.0	clause 8 (A1...F)
Any Other	Find similar mounting from cl.* 1.0 to cl. 11.0 or use 7.0	clause 8 (A1...F)

- (1.0) **LINEAR INSULATION PRODUCTS**, if not covered by harmonized product standard, shall be tested according to EN 15715 (fig. 2). EGOLF agreements EGA 004 and EGA 014 shall be used, taking into account that the steel pipes used to mount the insulation products shall have the outer diameter equal to the inside diameter of the insulation product. The distance between products and from products to the backing board is always 25 mm, as described in EN 15715. If different inside diameters are produced, 22 mm is valid for any other diameter, otherwise min. and max. inside diameter (single test) shall be tested, repeating twice in the most critical case. With diameter variation, the range of thickness shall be tested following par. 5.3.2.8.2 of EN 15715 (25mm, 50 mm, and 75 mm). Be aware, that insulation products with a thickness of facing or coating less than 3 mm are normally covered by the relevant harmonized product standards. Steel pipes are used to simulate any other metal pipe. If the internal tubes are made of a different material than metal, the test shall be carried out replacing the metal pipes with that material.
- (2.0) **INSULATED TUBES** (Fig. 3) shall be tested according to EN 15715 as insulation products (Fig. 2); an additional metal tube or metal brackets can be used to support plastic pipes during the test, preventing them from collapsing. Be aware, the classification according to clause 10 of EN 13501-1 refers only to insulation products. If an insulated tube is the subject of the classification, even if the rules for testing are the same, clause 8 of EN 13501-1 shall be applied for the final reaction to fire class.

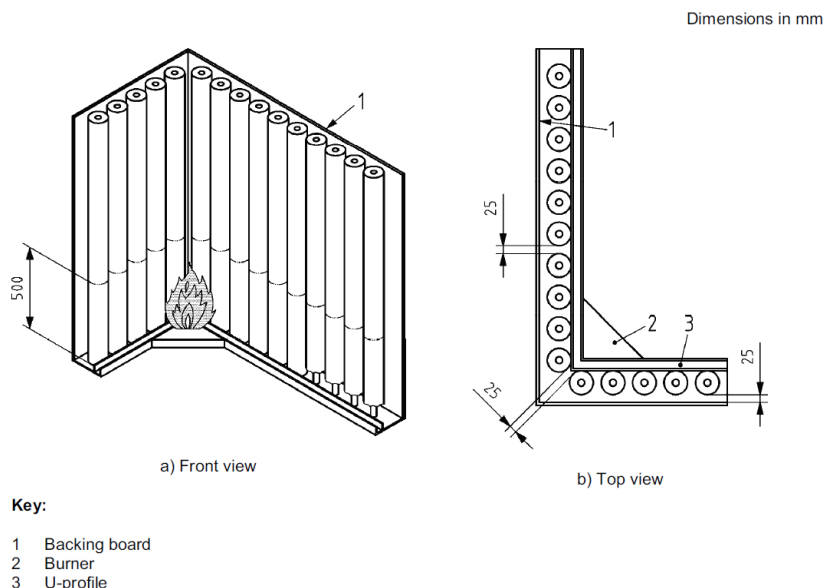

Fig 2. Mounting and Fixing EN 15715



Fig 3. Insulated pipe

- (3.0) **CHIMNEYS** and other products with a vertical orientation, as well **HANDRAILS** where the ventilation is almost parallel to the product in the end use condition and that are normally installed as a unique product (no similar to any other product),

shall be tested according to EGA 018. Diameter and linear density (kg/m) and wall thickness are considered “Influencing parameters”.

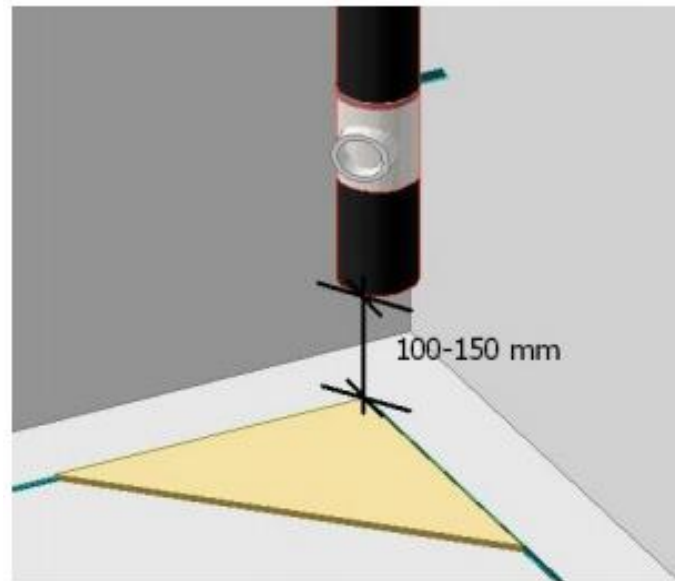

Fig 4. Mounting and Fixing EGA 018

- (4.0) **TUBES FOR GAS** can be tested according to EN 14800 or EN 15266. Even if the products are quite similar, the mounting and fixing are really different therefore it is not simple to make a decision on what kind of mounting shall be used for other similar products not covered by EN 14800 or EN 15266.

Figure B.1 gives the mounting instructions for reaction to fire of the pliable tubing exposed to the thermal attack by a single burning item. The test procedure is given in EN 13823.

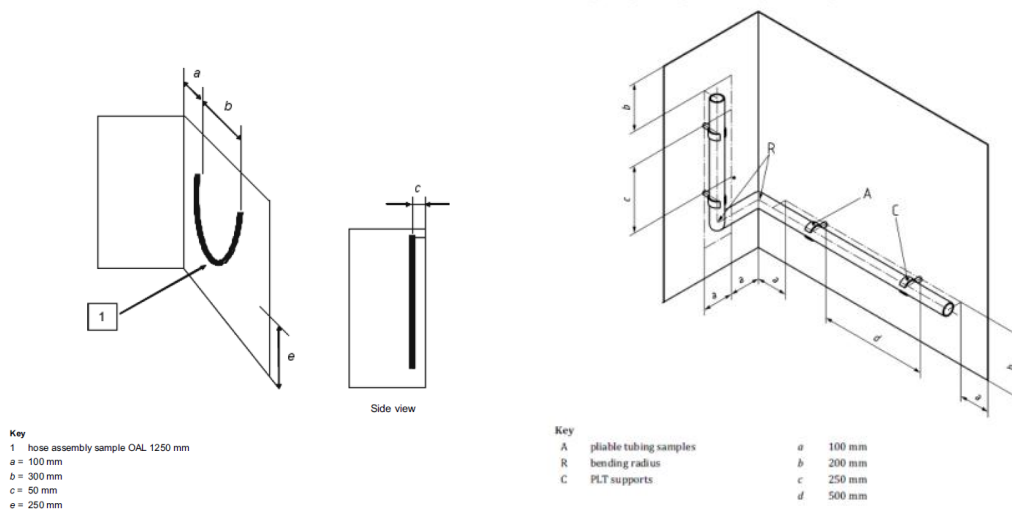

Fig 5. Mounting and Fixing EN 14800 and EN 15266

- (4.1) **PAINTED METALLIC TUBES FOR COMPRESSED AIR** should be tested according to EN 15266. If in end-use condition, two or more tubes are installed near each other, the mounting, par. 7.0, should be used (as AIR DUCTS).
- (4.2) **FLEXIBLE WATER SUPPLY TUBES** should be tested according to EN 14800.



Fig. 6 flexible water supply tube

(5.0) NON-PRESSURE PLASTICS PIPING SYSTEMS, FITTINGS AND THEIR JOINTS (not insulated pipes, described in the scope of EN 16000) shall be tested according to mounting and fixing of EN 16000, EN 15012, EN 15015, as described in the standard (DN110+DN40). Thickness is considered an “influencing parameter”. Considering:

- thickness 2 as the maximum thickness from DN110
- thickness 3 as the minimum thickness from DN110
- thickness 1, as the maximum thickness from DN40,
- thickness 4 as the minimum thickness from DN40

The test protocol is:

Test 1 DN110 mm with a thickness 2 and diameters DN40 mm with a thickness 1

Test 2 DN110 mm with a thickness 3 and diameters DN40 mm with a thickness 4

And 2 additional SBI tests must be carried out on the worst case.

The classification is valid for all diameters and for thicknesses ranging from 1 to 4, up to DN 110, in connection with pipes up to DN 40.

In the case of a single thickness test for one or both DN, the classification will be limited to that specific thickness for that specific DN.

In case the given dimensions do not exist, a single diameter for both tubes creating the “T-specimen” can be used, and the minimum and maximum diameter shall be tested as an indicative test:

- Test 1a: test the minimum diameter with minimum & maximum thickness
- Test 1b: test the maximum diameter with minimum & maximum thickness, concluding the test with the worst case.

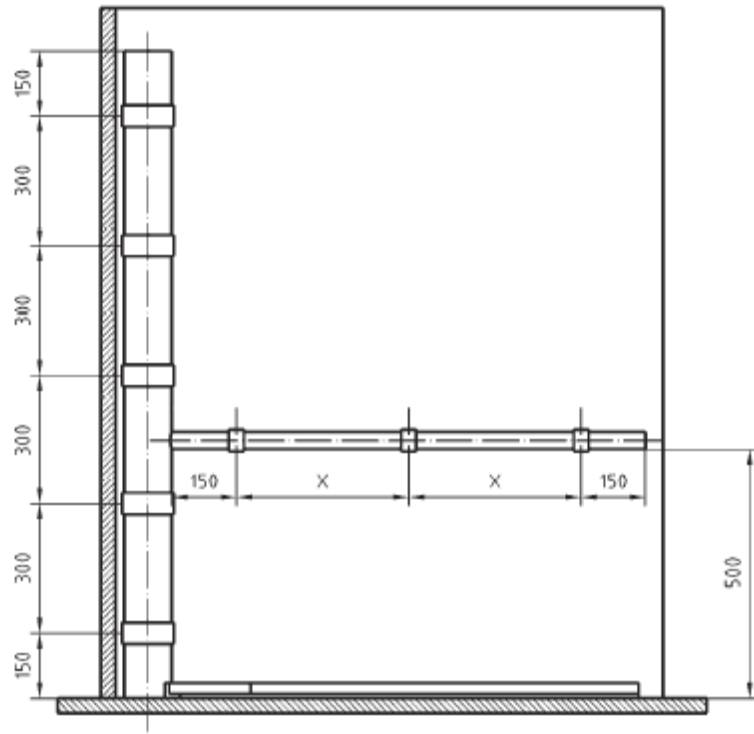

Fig. 7 Mounting and Fixing EN 16000

(6.0) SEALING PRODUCTS

(6.1) **GASKETS** shall be tested by applying the products on a substrate (EN 13238) using a metallic wire or any other system provided by the sponsor, fixing the test specimen at each end and every 300 mm from the floor corner. The gaskets shall be mounted on the long wing creating a “T-specimen” with two vertical products, starting with the first gasket at “X” mm from the edge, where “X” is the thickness of the substrate; the second is then fixed at 100 mm from the first gasket. One horizontal specimen at 500 mm from the floor of the SBI creates the “T-specimen”. Another gasket shall be mounted in the short wing, at 100 mm from the edge. Fig 8 shows the mounting of the gaskets on the long and short wings. Shape and linear density (kg/m) are considered “Influencing parameters. If the distance between two parallel gaskets in end-use is less than 100 mm, another gasket shall be mounted in the long wing and one in the short wing at 50 mm from the gasket mounted in the corner. This mounting is also representative of linear/pipe application under end-use condition.

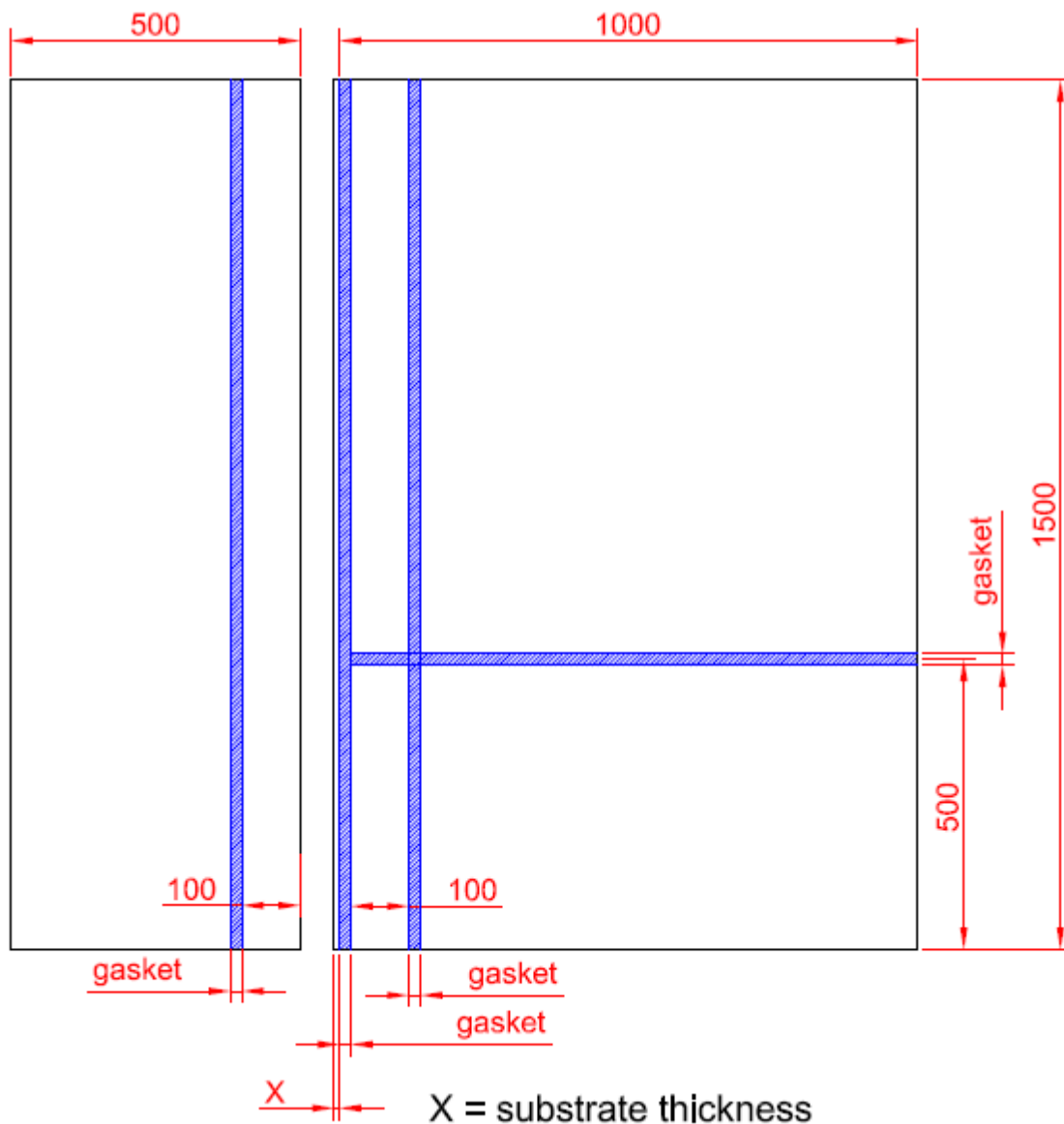

Fig. 8 gaskets on the long and short wing (quote in mm)

(6.2) **SEALANTS** shall be mounted in the long wing as shown in Fig. 9 and shall be fixed creating three joints, two with the following measures: 20 mm x 10 mm x 1500 mm and one: 20 mm x 10 mm x 1000 mm (width x depth x length) as described in the standard EN 15651-2, this is the minimum width x depth, if the product is applied with a greater amount in the end use conditions, that specific width x depth shall be used. Another seal of the same width x depth x length shall be mounted in the short wing, at 100 mm from the edge. Calcium silicate with a thickness of 20 mm and a density of $870 \pm 50 \text{ kg/m}^3$ or any other substrate as described in EN 13238 should be used as substrate. Linear density (kg/m) is considered “Influencing parameter”. If in end use the distance between two parallel sealants is less than 100 mm, another sealant shall be applied in the long wing and one in the short wing at 50 mm from the sealant mounted in the corner. This mounting is also representative of linear/pipe application under end-use condition.

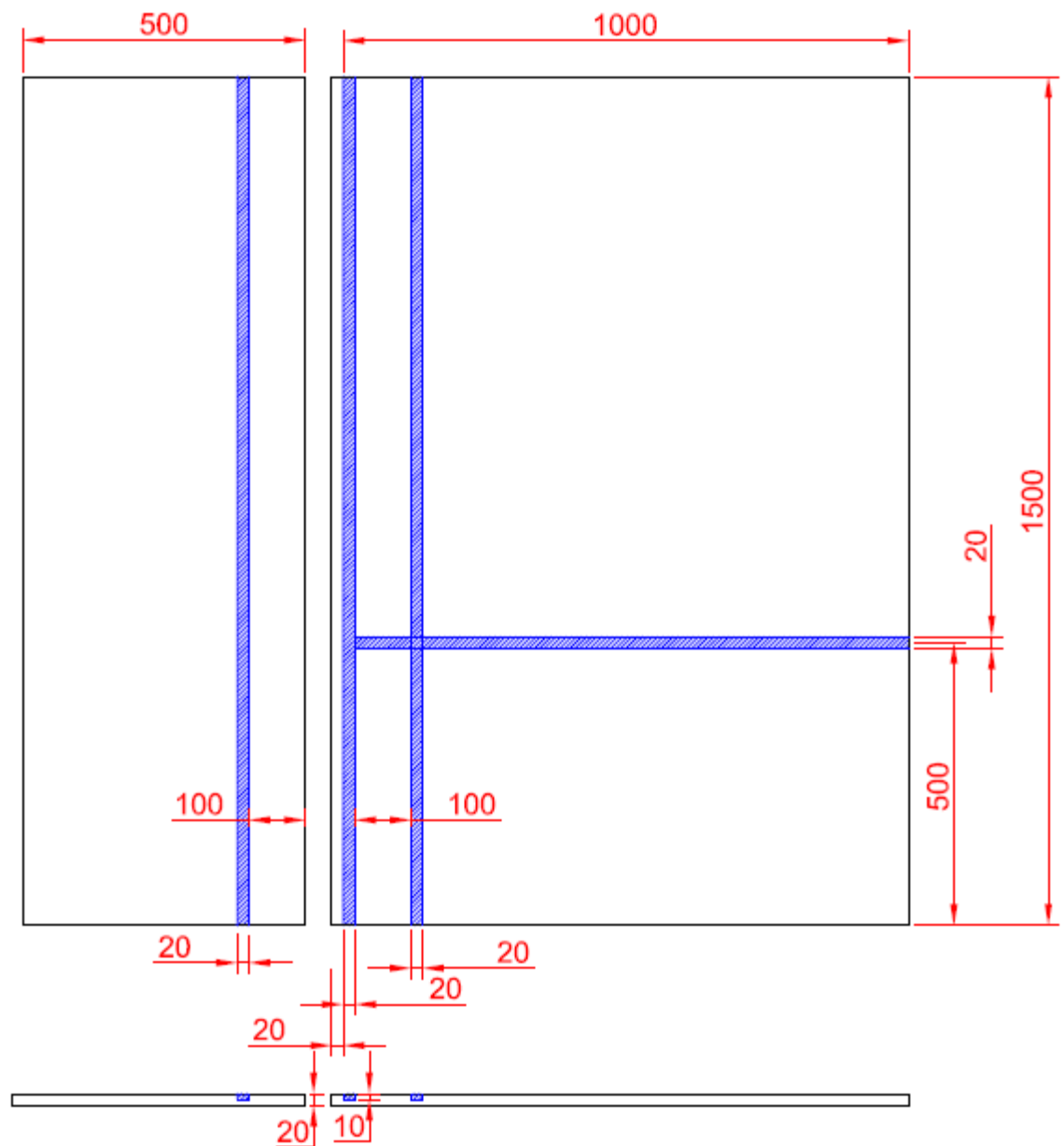
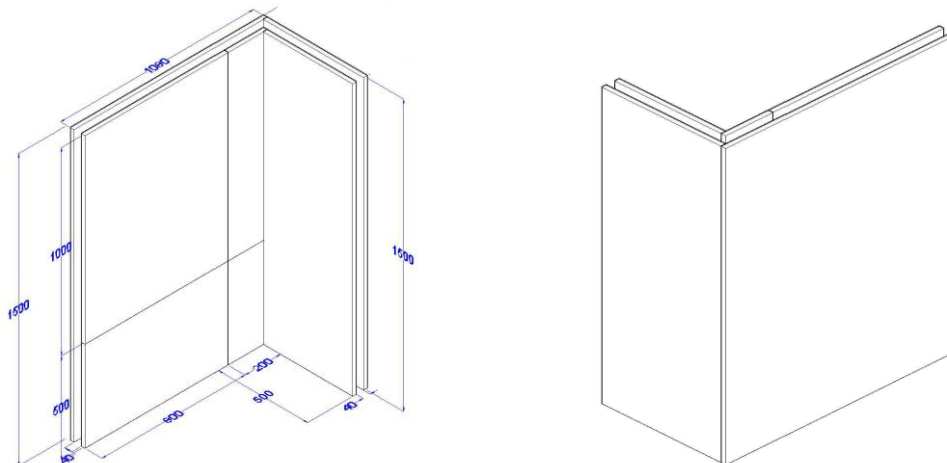

Fig. 9 Sealants on the long and short wing (quote in mm)

- (6.3) **FIRE STOPPING AND FIRE SEALING PRODUCTS – Linear joint and Gap seal** shall be tested covering the entire area of the substrates as described in the EAD 350141-00-1106.
- (6.4) **JOINTING MATERIALS** for gypsum boards (EN 13963) shall be tested by filling only the vertical (200 mm) and horizontal joint (500 mm). Where the jointing system requires the compound to be applied to the whole surface of the board, the test shall be carried out with the surface coated with the highest recommended thickness.
- (6.5) **FIRE STOPPING AND FIRE SEALING PRODUCTS – PENETRATION SEALS** shall be tested as described in the EAD 350141-00-1104.
- (7.0) **AIR DUCTS AND PLASTIC DUCTS FOR WIRE (This document supersedes EGA 019-2016)** shall be tested only with vertical orientation. Ducts must be tested for both minimum and maximum diameters or cross section for rectangular/square ducts, and shall be tightly placed next to each other, hung from a calcium-silicate substrate board. Ducts shall fully cover the short and long wings of the SBI test specimen. In order to test products with an outer diameter > 200mm, the ducts shall be reshaped, then a flat version comprising a vertical (200 mm) and horizontal (500 mm) joint shall be tested, with a ventilated cavity of 40 mm. In the case of testing ducts made only of insulation panels, or plastic or multilayer materials, the substrate is represented by exactly the same product, to consider as a specific substrate, which is then mounted as free-standing. In the case of a metallic insulated air duct, the metallic substrates indicated in EN 13238 might be used as substrates. In that case, the rear part of the metallic duct shall be 40 mm away from the metallic substrate, which is mounted as a free-standing. To fix the product, if needed, a metal frame might be used, and the specimens can be fixed using screws and washers, one on each corner. Be aware that these products exhibit completely different fire behavior when tested as flat specimens or ducts.



PLASTIC DUCTS FOR WIRE shall be tested following the rules of air ducts. Shape, thickness of the wall and diameter/overall thickness are considered “Influencing parameters”; for rectangular forms with a variation of width, only the minimum width shall be tested. To fix the plastic ducts on the substrates, means provided by the sponsor or metallic wires can be used, fixing the specimen every 300 mm from the floor of SBI trolley

- (8.0) **ADHESIVES TAPES** shall be attached to the required substrates with vertical and horizontal orientation, tightly placing all the strips next to each other. The substrates on each wing shall be fully covered by the tapes. Check the worst orientation with

an indicative test and if the worst parameter for classification differs more than 20%, add two more tests in the worst case, otherwise add only one more test, since the orientation is not relevant. Only the minimum width shall be tested and results are valid for all other larger tapes.

(9.0) THERMOPLASTIC JACKETS FOR INSULATION PRODUCTS The requirements of Table 3 "Classes of reaction to fire performance for linear pipe thermal insulation products" of EN 13501-1:2007 apply as the classification criteria of the cladding. The reaction to fire test of the cladding shall be carried out linearly according to EN 15715 on glass wool pipe sections with an insulation thickness of 30 mm. When testing according to EN ISO 11925-2, the cladding shall be subjected only to surface flame impingement. The film shall be fastened to the pipe sections with rivets. For the test, the film shall be aligned with the closing seam in the direction of the back plate

(10.0) PREFORMED PLASTERBOARD CORNICES. The specimen, with a length of 1500 mm shall be attached to the substrates, using a gypsum-based adhesive EN 14496 at the angle between the two wings. If the base of the cornice extends further in one direction, this portion should be attached to the long wing. Additionally, the substrate used for the short wing should be positioned against the U-profile, as well as the external side of the cornice. Any variation in shape and form or density shall be tested.

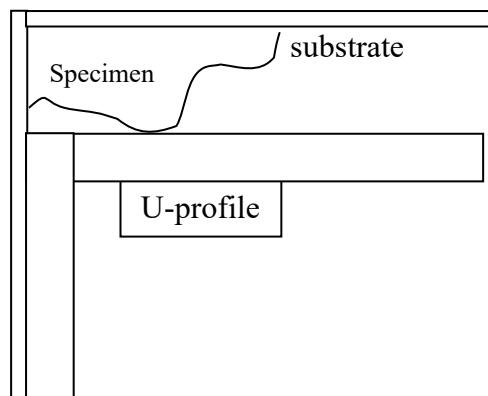

(11.0) DUCTWORK - NON-METALLIC DUCTWORK . The specimen shall be tested as indicated in EN 17192, with this additional information:

- “The wall of the test rig” in 8.5.2 “Test configurations for SBI test” is intended for the substrate as EN 13238
- The short-wing substrate shall be placed against the U-Profile, see Fig. 6 and 7 of the EN 17192
- The ducts, fixed in the long wing, shall be placed against the U-profile.
- For ducts with a diameter greater than 200 mm, clause 7.0 of this document applies.